

EXTERNAL WIRING-MODEL LSSC W/O OPTION 2

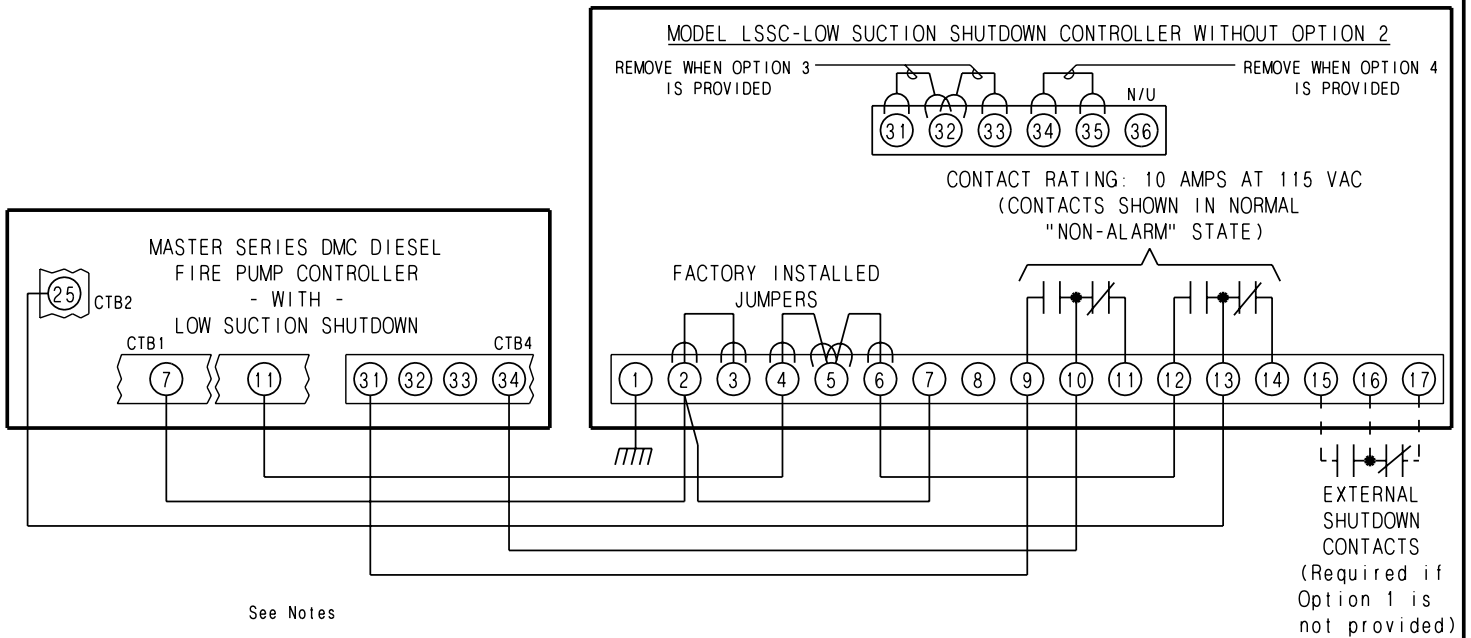

EXTERNAL WIRING-MODEL LSSC WITH OPTION 2

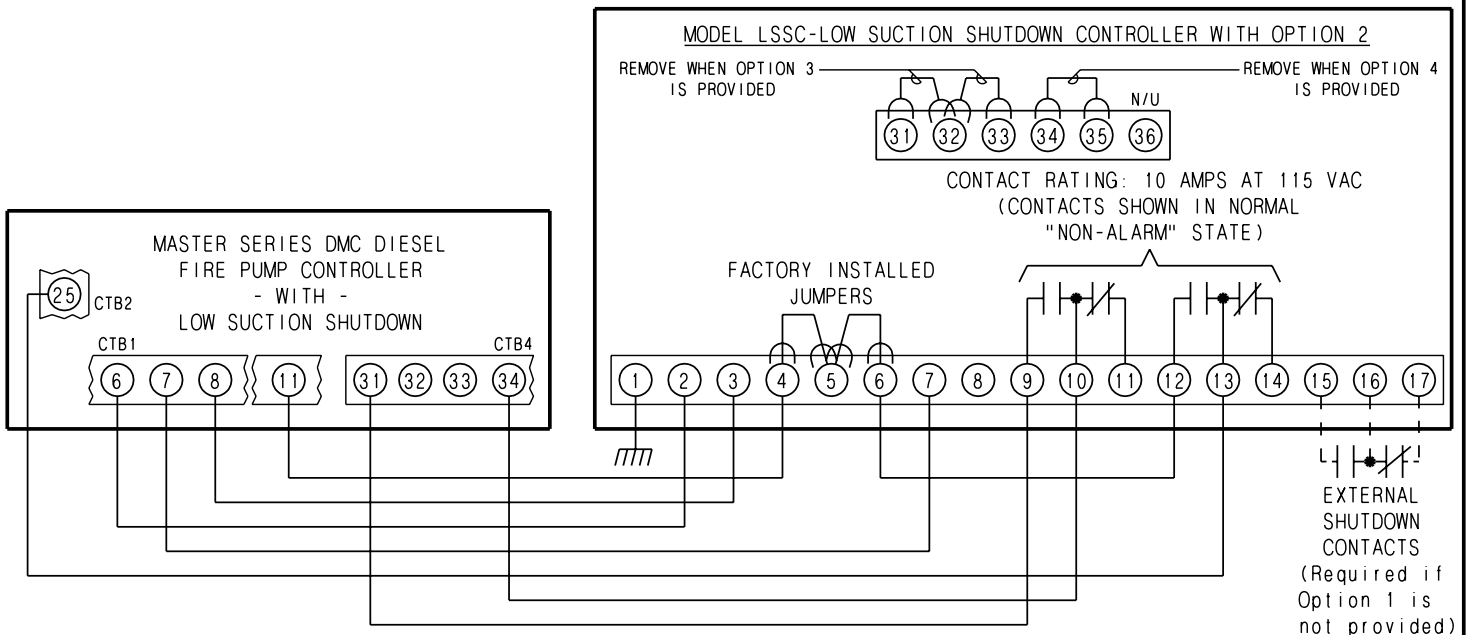

This drawing applies to series 'LSSC' Low Suction Shutdown Controller with any or all of the following optional features:

1. PRESSURE SWITCH SHUTDOWN
2. DUAL INPUT POWER
3. REPETITIVE ALARM SIGNAL
4. AUTOMATIC RESET RELAY

NOTES:

1. Only ONE controller may be wired to the LSSC at any one time.
2. Diesel controller must be equipped with Option 'O'. Low Suction Shutdown.

EXTERNAL WIRING FOR MODEL LSSC LOW SUCTION SHUTDOWN CONTROLLER FOR DMC CONTROLLERS	
MC MASTER CONTROL SYSTEMS INC. LAKE BLUFF, ILLINOIS U.S.A.	
DRN: <i>2</i>	REPLT 13 DEC. 08
APP:	DATE 2 DEC. 08
DWG: 18761	ISS: 1 SHEET 1 OF 1