

MC Single Source Fire Pump Controller

MASTER

Model	Short Circuit Current Rating	Maximum Horsepower				
		200/208	220-240	380/415	440-480	550-600
MCA						
MCP	100,000A	150	200	350	400	400
MCO						



NOTES:

- CONSTRUCTION:** NEMA TYPE 2, 12, 3R, & 4
- FINISH:** FIRE PUMP RED
- CONDUIT ENTRANCE:** CONDUIT ENTRY ON TOP OR BOTTOM. PROTECT EQUIPMENT FROM DRILLING CHIPS
- CONDUIT HUBS:** WATERPROOF HUBS REQUIRED FOR TOP ENTRY
- ACCESS:** FRONT
- MOUNTING:** FLOOR MOUNT
- SHIPPING WEIGHT:** 530 LBS. (240 KG) MAX.

DIMENSIONS IN INCHES AND [CENTIMETERS]

1/2" FEMALE N.P.T. NOMINAL (TRADE SIZE) AMERICAN STD. TAPERED PIPE THREAD

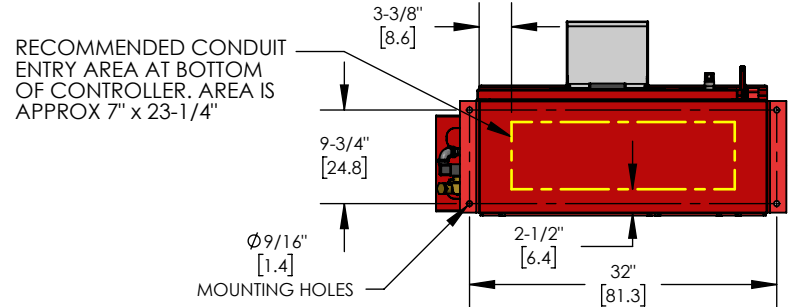
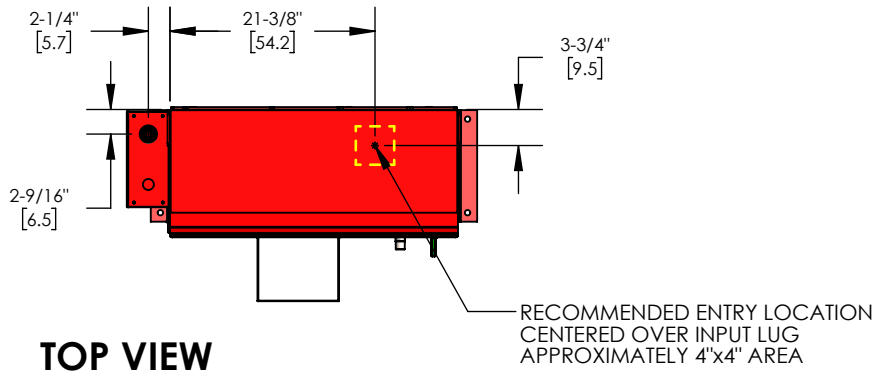
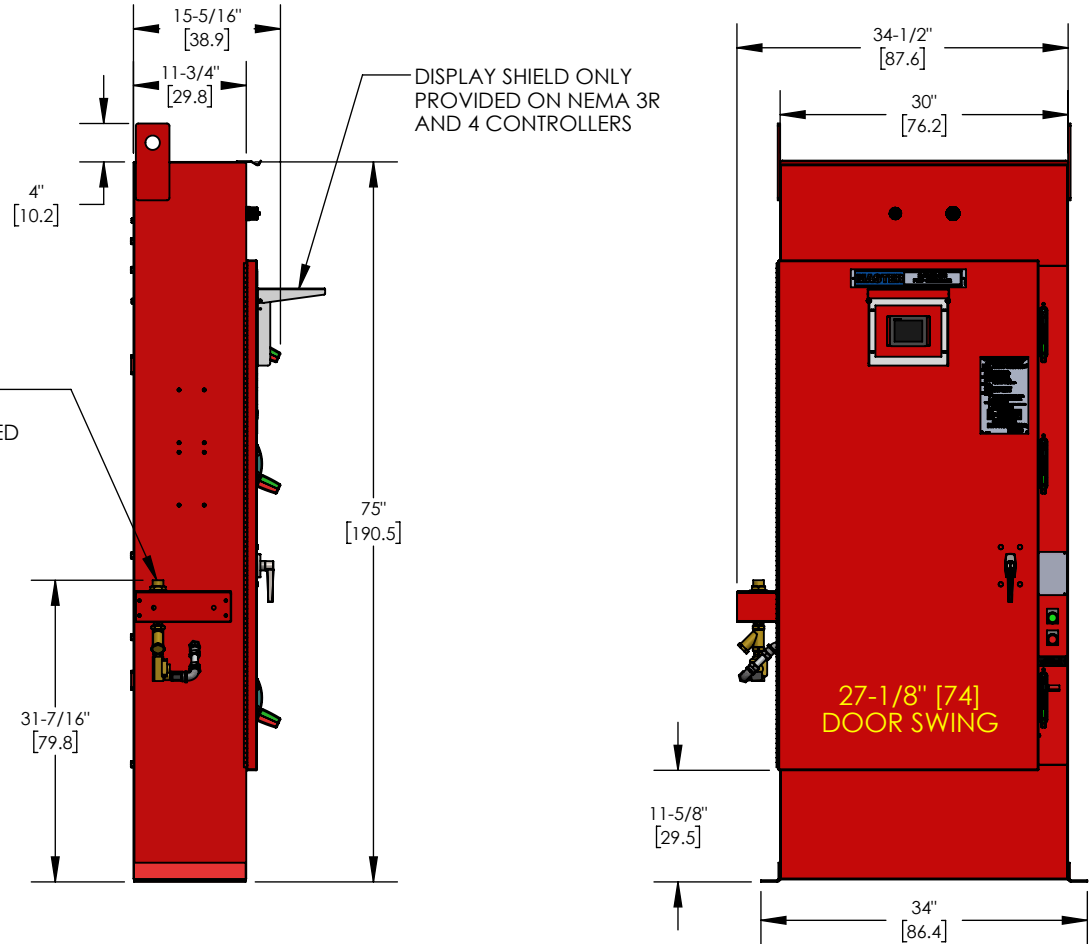

TOP VIEW