

# ECV Variable Speed Transfer Switch Fire Pump Controller

**MASTER**

Model	Short Circuit Current Rating	Maximum Horsepower			
		200/208	220-240	380/415	440-480
ECVAT	100,000A	150	150	350	400
ECVRT		150	150	200	300
ECVST		100	125	200	250



**Notes:**

- Construction:** NEMA Type 12
- Finish:** Fire Pump Red
- Conduit Entrance:** Conduit Entry on Top or Bottom. Protect Equipment from Drilling Chips
- Conduit Hubs:** Waterproof Hubs Required for Top Entry
- Access:** Front
- Mounting:** Floor Mount
- Shipping Weight:** 1,750 Lbs. (794 kg) Max.

1/2" (13mm) Female N.P.T. Nominal (Trade Size) American Std. Tapered Pipe Thread

Dimensions In Inches and [Centimeters]

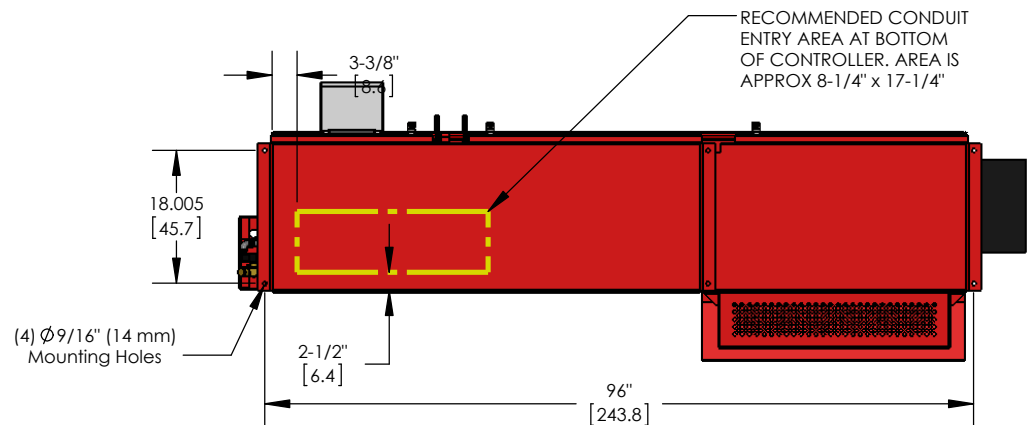
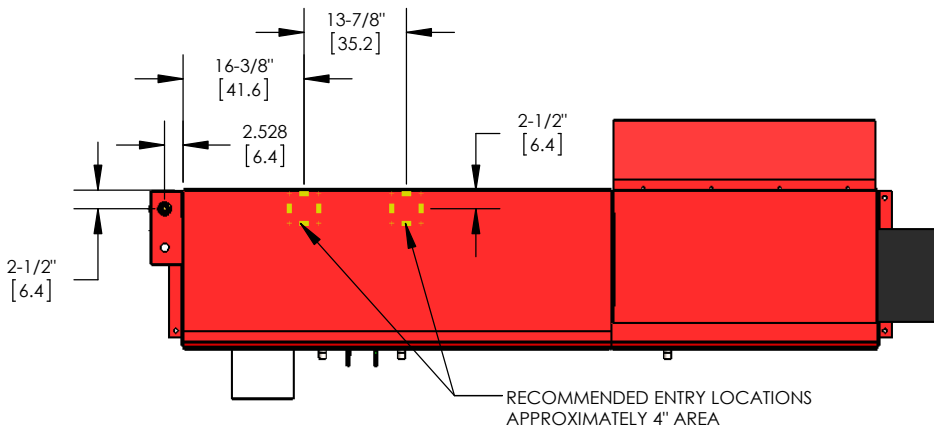
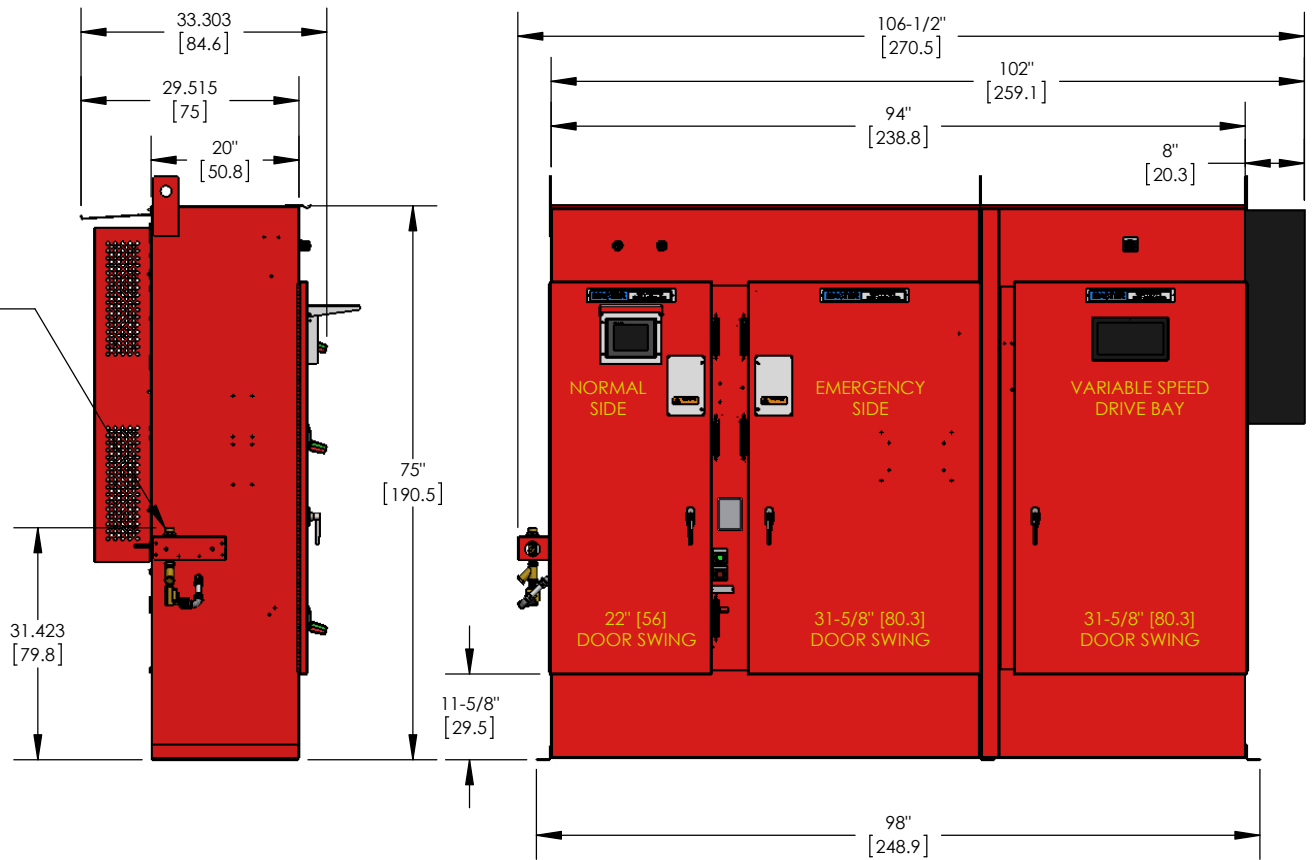

**TOP VIEW**