

ARC FLASH MITIGATION

NFPA 20 addresses Arc Flash in the 2022 edition



ARC FLASH FOR A FIRE PUMP CONTROLLER

The arc flash energy available at the input terminals of a fire pump controller can be extremely high or unlimited!



DANGER

**NO SAFE PPE EXISTS
ENERGIZED WORK PROHIBITED**

IT'S SO HIGH THAT...

“Hot” work can't be safely conducted on a typical fire pump controller.

Let's see why...

A real test lab video

To see video, go to:

www.mastercontrols.com

Click on the 100,000 AMPs video play
button on the home page

WHY IS THE ENERGY SO HIGH?

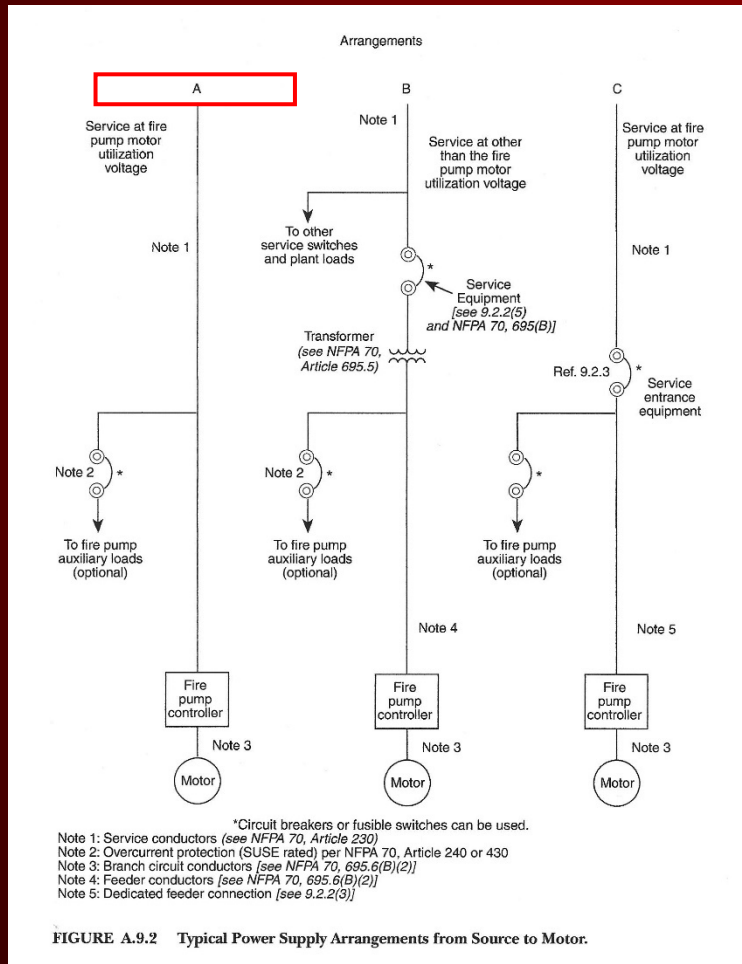

- NFPA 20, Arrangement A

- The power source to the fire pump controller is a Service directly from the utility for the best reliability. NFPA 20 9.2.2(1), NEC 695.3(A)(1).
- The building Service overcurrent protection on the utility side is likely to be so large that it won't trip on an arc fault in the fire pump controller.

WHY IS THE ENERGY SO HIGH?

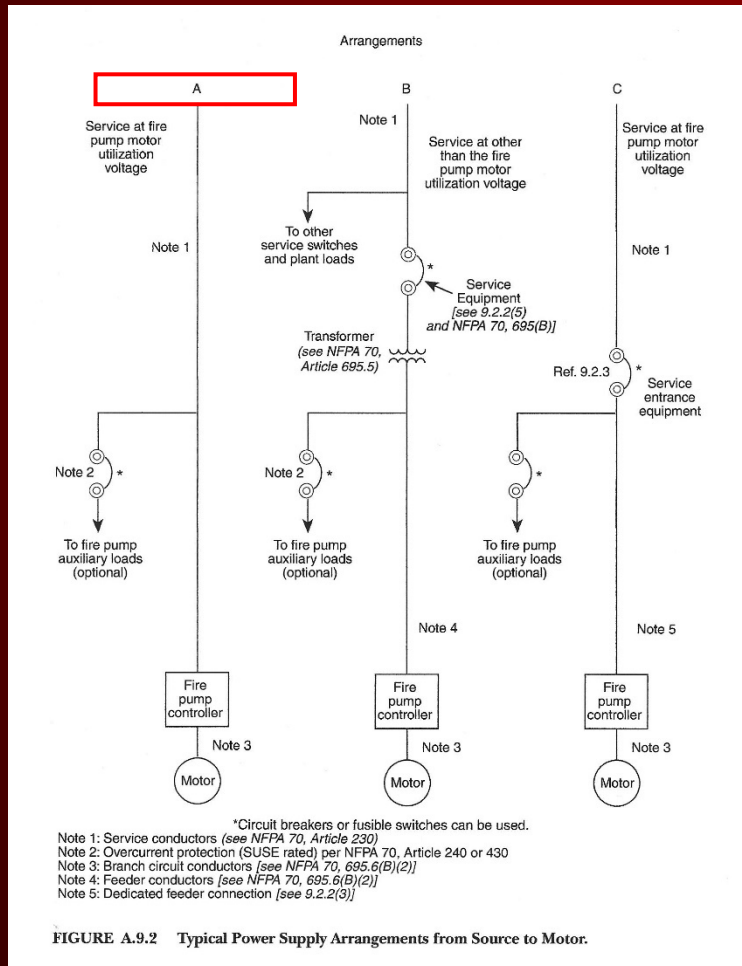

• Arrangement A (cont'd)

- Wire brought to the controller for a 250 hp, 460 vac motor will be 500 kcmil/phase so the short circuit current can be 100 kA.
- The incident energy for this circuit can't be calculated if the line side circuit protection doesn't trip.
- Thus, energized work is prohibited. To work on the fire pump controller, the building power must be shutdown by the utility. This make trouble shooting very difficult.

OTHER ARRANGEMENTS

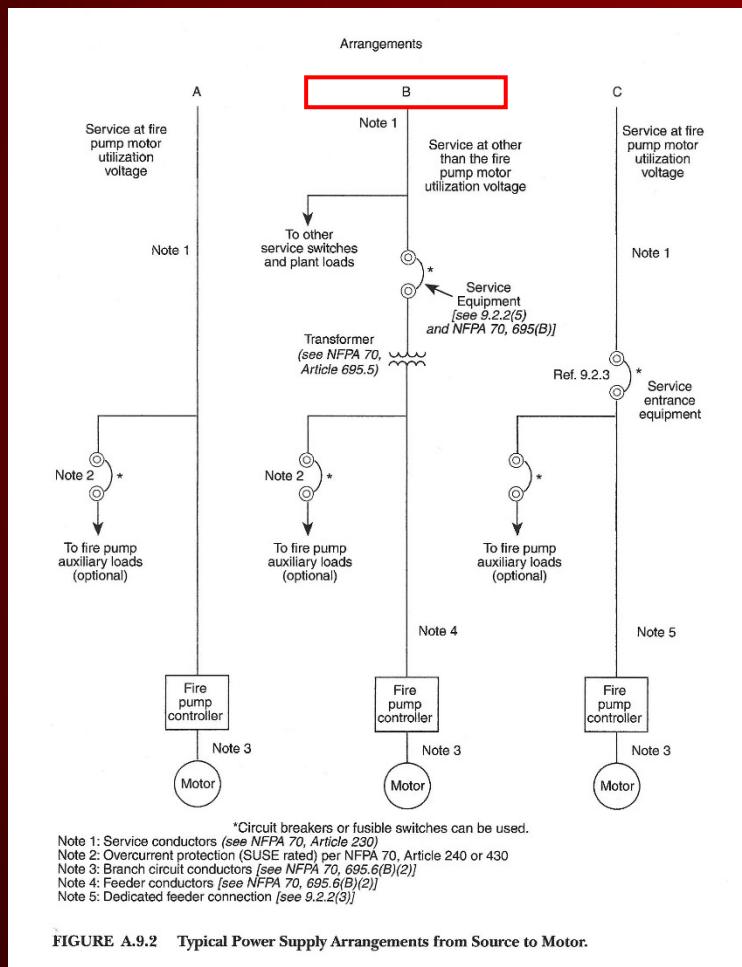

- NFPA 20, Arrangement B

- If the Service voltage is greater than the utilization voltage, a dedicated transformer is required per NFPA20 9.2.2(5) and a service disconnect per NFPA20 9.2.3, NEC 695.4(B)(1).
- The overcurrent protection for the transformer is to be sized for locked rotor current per NEC 695.5(B).
- For a 250 hp, 460 vac motor, the locked rotor protection will be sized for 2000 amps.
- The incident energy at the controller can now be calculated but will be quite high.

OTHER ARRANGEMENTS

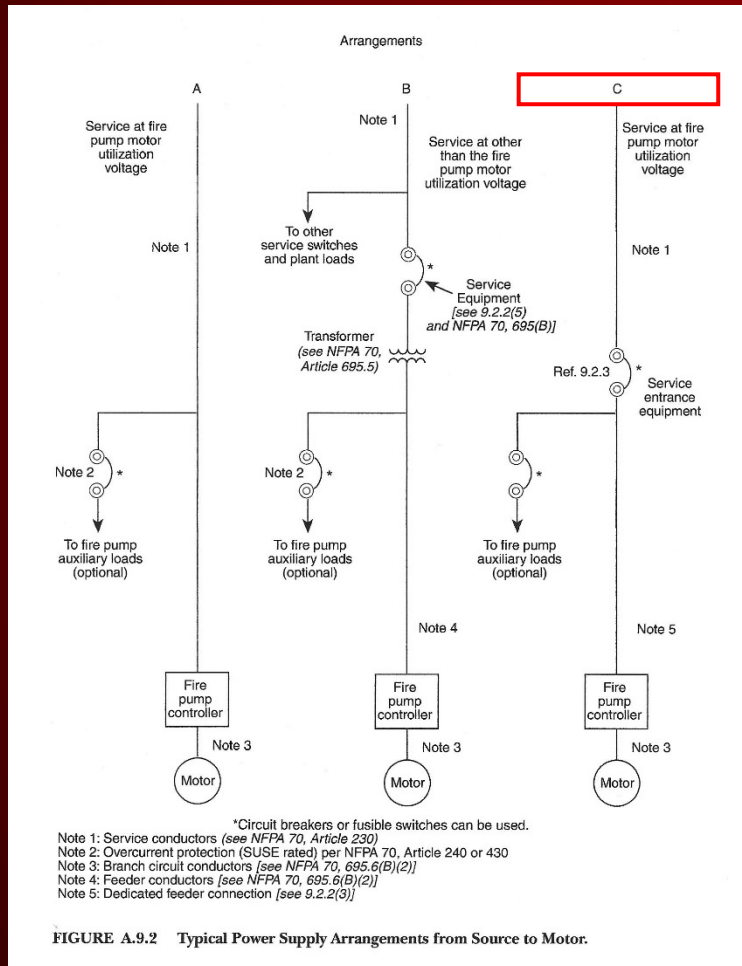

- NFPA 20, Arrangement C

- A single service disconnect is allowed per NFPA20 9.2.3 or NEC 695.4(B)(1).
- The overcurrent protection is typically sized to 9.2.3.4 or NEC 695.4(B)(2)(a)(1) for locked rotor current.
- For a 250 hp, 460 vac motor, the locked rotor protection will be sized for 2000 amps.
- The incident energy at the controller can now be calculated but will be quite high.

NFPA 20 – 2022 ARC FLASH MITIGATION CHANGES

Chapter 10

- 10.1.4 Arc Flash Mitigation for Personnel Protection. Controllers shall be provided with arc flash mitigation in accordance with 10.1.4.1 or 10.1.4.2.
- 10.1.4.1 Construction
- 10.1.4.1.1 Controllers shall be constructed so that the isolating switch, with instantaneous-only overcurrent protection, is located in a separate enclosure or compartment attached to the controller.

NFPA 20 – 2022 ARC FLASH MITIGATION CHANGES

Chapter 10 (cont'd)

- 10.1.4.1.2 The construction of the separate enclosure or compartment shall be both of the following:
 - (1) Able to totally isolate incoming normal power from the main enclosure
 - (2) Marked to prohibit energized work
- 10.1.4.2 Controllers shall be listed as arc resistant.

NFPA 20 – 2022 ARC FLASH MITIGATION CHANGES

Chapter 14

- 14.2.3.1 The arc flash risk assessment required by NFPA 70E or an approved local equivalent shall be performed for all electric fire pump controllers.
- 14.2.3.2 Electric fire pump controllers shall be field labeled for arc flash risk in accordance with NFPA 70E or an approved local equivalent.

Note: This field labeling is not done by the fire pump controller manufacturer.

SO FOR THE BEST MITIGATION TECHNIQUE

- Use Arrangement A with SIS

- This uses a Service directly connected to the fire pump controller for highest reliability. NFPA 20 9.2.2(1), NEC 695.3(A)(1).

- Adds Modification SIS to the fire pump controller for Arc Flash Mitigation and Personnel Protection in accordance with NFPA 20 10.1.4.1

- The arc flash incident energy with the SIS has been verified by an independent NRTL laboratory to be less than 0.5 cal/cm².

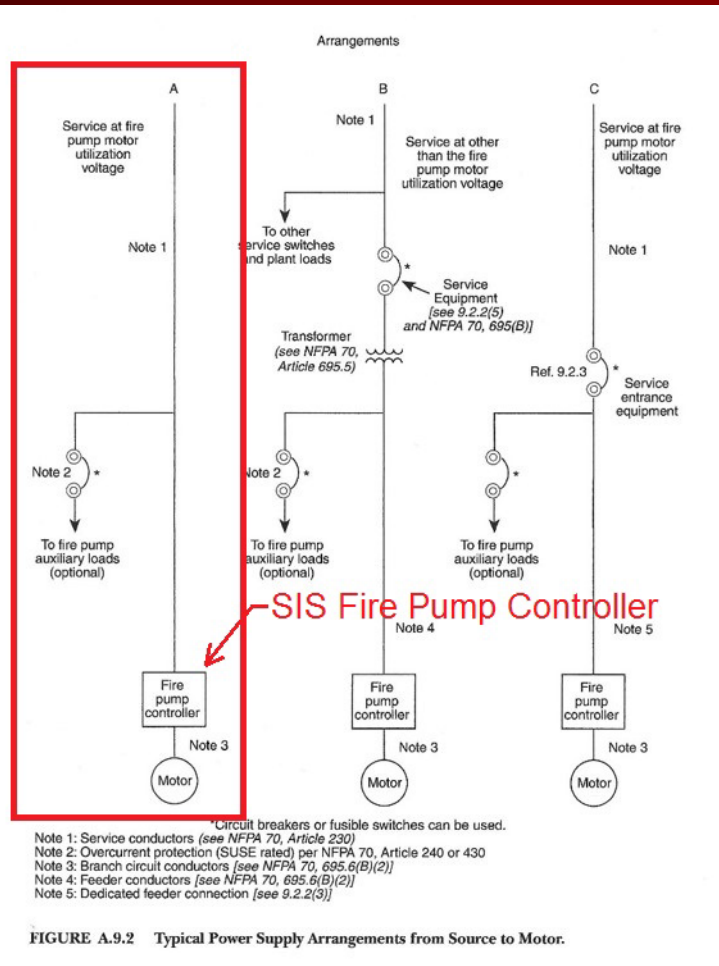

INSTALLED SIS FIRE PUMP CONTROLLER



- SIS compartment is located on the far left side.
- Incoming power allowed from the top, but must be installed with waterproof hubs.
- Other compartments from left to right are the fire pump controller, transfer switch, reduced voltage, and variable speed.

MASTER Model ECVST-350-46-XG4,SIS

MITIGATION TECHNIQUE



- MASTER Modification SIS
 - Moves Isolating switch into a separate enclosure in accordance with NFPA 20 10.1.4.1.
 - Locally disconnects power to main fire pump controller.
 - Reduces the Arc-Flash incident energy in the fire pump controller main cabinet to less than 0.5 cal/cm².
 - Verified by an independent NRTL laboratory.
 - Fire stop used in connecting conduit.
 - Allows “hot” work with basic PPE.
 - Substantially reduces typical arc flash mitigation costs.