

MASTER

**REMOTE ALARM PANEL
INSTRUCTION MANUAL**

SERIAL NO.

MODEL NO.

SRAP



MASTER CONTROL SYSTEMS, INC.

P.O. BOX 276 • 910 NORTH SHORE DRIVE • LAKE BLUFF, ILLINOIS 60044, USA

TELEPHONE: 847-295-1010 • FAX: 847-295-0704

www.mastercontrols.com

MODEL SRAP

REMOTE ALARM PANELS

Table of Contents

Installation Instruction	1
General Information	4
Operating Procedures	4
Theory of Operation	5
Replacement Parts List	6
Schematic Diagram	
External Wiring	

INSTALLATION INSTRUCTIONS

FOR

SERIES SRAP ALARM PANELS

These Remote Alarm panels are designed for remote monitoring and supervision of Fire Pump installation. They should be mounted at a point of constant attendance such as a guardhouse, switchboard, or the like. This is to meet the requirements of NFPA 20 when the pump room is not constantly attended (NFPA 20-1980, Par. 7-4.5 & 9-4.2).

The alarm panel cabinet must be surface wall mounted in a vertical position. The cabinet must be mounted indoors and must not be located in areas subject to falling or spraying water. Four external mounting ears having 5/16 inch holes (or slots) are provided to accept 1/4 inch mounting bolts. The unit weight is less than 25 pounds. Refer to MOUNTING DIMENSION drawing for mounting size and hole locations.

Knockouts are provided for conduit entry. The unit should be powered by a local A.C. power branch circuit. The power requirements of the alarm panel is less than one ampere. Refer to the EXTERNAL WIRING DIAGRAM for wiring information. The A.C. input power wires need not be larger than 14 AWG. Refer to the alarm panel NAMEPLATE for required A.C. power voltage and frequency. The unit is provided with a bonding terminal for use with wired ground systems.

The unit has an isolated S.P.D.T. (Form "C") contact for wiring to a remote external alarm device or alarm system or central station. Source and signal is by others.

TABLE 1 - FIELD WIRING CONNECTIONS

<u>TERMINAL</u>	<u>MINIMUM WIRE SIZE (COPPER)</u>	<u>DESIGNATION</u>
TB1-3 (GND)	--As Required--	Chassis Ground--Connect to ground wire of a three prong line cord when used. Connect to ground wire in a conduit wired installation when a wired ground is required. (The chassis is not insulated from the cabinet).
TB1-1 (AC-H)	--14 AWG-- (Code)	A.C. Power Input Terminal (high side, fused side)--Connect to high side of A.C. supply if fused (or breakered) consistent with the nameplate A.C. current requirements. A slo blow or time-lag fuse or breaker is preferred.

INSTALLATION INSTRUCTIONS - (Continued)

TABLE 1 - FIELD WIRING CONNECTIONS - (Continued)

<u>TERMINAL</u>	<u>MINIMUM WIRE SIZE (COPPER)</u>	<u>DESIGNATION</u>
TB1-2 (AC-N)	--14 AWG-- (Code)	A.C. Power return Terminal--Connect to low or neutral side of A.C. supply.
TB1-4	--#16 AWG--	N.O. to
TB1-5	--#16 AWG--	COM. Remote
TB1-6	--#16 AWG--	N.C. Alarm Device
TB2- and Above	See Table 2 and Table 3	Alarm Circuit (See Schematic) Common

The following calculations are based on a 10% loop drop. The signal voltage is 24 VDC, unfiltered, from the alarm set and is not a Class 2 signal and is isolated from the line. Max current per alarm circuit is 100mA maximum.

Technical: The alarm current draw is 2.4 mA for each of two common relays and 50 mA per alarm lamp. Maximum draw per alarm is approximately 100 mA for the first alarm and 50 mA each after. The maximum loop resistance is 75 ohm. The maximum run resistance is 35 ohm.

Table 2 shows maximum RUN lengths if multiple common wires are used (one per alarm -or- one pair of wires per signal). E.G., 8 wires for a SRAP.

TABLE 2

WIRE SIZE	RES/1000 FT.	MAX. RUN LENGTH
#12 AWG	1.588 ohm	22,000 ft.
#14 AWG	2.525 ohm	14,000 ft.
#16 AWG	4.016 ohm	9,000 ft.
#18 AWG	6.385 ohm	5,500 ft.
#20 AWG	10.15 ohm	2,500 ft.
#22 AWG	16.14 ohm	2,200 ft.
#24 AWG	25.67 ohm	1,400 ft.
#26 AWG	40.18 ohm	900 ft.

Table 3 shows maximum run lengths if only a single common wire is used (E.G., total of 5 wires for a SRAP-4) and is the same size as the signal wires.

INSTALLATION INSTRUCTIONS - (Continued)

TABLE 3

WIRE SIZE	MAX. RUN LENGTH IN FEET							
	NO. OF ALARM CIRCUITS (SRAP(-X); VALUES OF "X")							
	-3	-4	-5	-7	-9	-10	-13	-15
#12 AWG	19,000	15,000	12,500	9,400	7,500	7,000	5,400	4,700
#14 AWG	12,000	9,500	7,900	5,900	4,700	4,400	3,400	3,000
#16 AWG	7,500	6,000	5,000	3,700	3,000	2,700	2,100	1,800
#18 AWG	4,700	3,700	3,100	2,300	1,900	1,700	1,200	1,100
#20 AWG	3,000	2,400	2,000	1,500	1,200	1,100	800	700
#22 AWG	1,800	1,500	1,200	900	750	700	500	450
#24 AWG	1,200	900	800	600	500	400	330	300
#26 AWG	750	600	500	400	300	270	200	180
MAX. COMMON DRAW	200mA	250mA	300mA	400mA	500mA	550mA	700mA	800mA
MAX. COMMON RES.	30 ohm	24 ohm	20 ohm	15 ohm	12 ohm	11 ohm	8.6 ohm	7.5 ohm

These values are valid only when the alarm set is powered locally.

All alarm wiring must be isolated from line & ground.

GENERAL INFORMATION

MODEL SRAP REMOTE ALARM PANEL

The Remote Alarm Panel (SRAP) provides individual failure signal lamps, audible alarm, and isolated failure alarm contacts factory wired to terminals external remote device or circuit.

Also furnished are: A.C. primary & secondary fuses, F1 & F2 respectively and power on indicating lamp; a test switch for checking the proper functioning of alarm circuits, signal lamps, audible alarm and isolated alarm contacts; and an alarm silence switch for silencing the audible alarm.

Repetitive alarm circuit are provided. With this circuit a recurring failure will still sound the audible alarm even though the alarm silence function has been initiated.

When a failure occurs the related signal lamp energizes. The circuit senses this failure and energizes the audible alarm and external remote alarm. The Remote Alarm Panel remains in this alarm state until the initiating failure cause is corrected.

The audible alarm may be silenced by actuating the Alarm Silence switch, this however, has no effect on the related failure signal lamp which will remain energized until the failure cause is corrected.

Should recurring failures occur on the designated repetitive alarm circuit, after the audible alarm has been silenced, the circuit will again sound the audible alarm.

OPERATING PROCEDURES

To Place Alarm Panel Into Operation, connect to a local A.C. power branch circuit. The "ON" lamp will light to indicate the alarm panel is in the standby condition, ready to initiate the alarm circuit(s) should a failure(s) occur. Failures are sensed by the alarm panel through external (normally open) failure contacts connected to the alarm panel terminals, (See Schematic).

To Silence the Alarm(s) momentarily operate the Alarm Silence switch SW2 to energize relay RK21. Contacts RK21B opens to de-energize relay RK11. Contacts RK11A open to de-energize the audible alarm & relay K1. Contacts K1A & K1B transfer back to normal to de-energize the external remote alarm or alarm device. Contacts RK11B & RK21A close to seal-in relay RK21 through closed RK2A contacts.

TO TEST ALARM CIRCUITS momentarily operate the "Test" switch which simulates the closing of all alarm failure contacts. This will cause all alarm lamps to light and the audible alarm and external remote alarm to become energized in the same sequence as previously described. Releasing the "test" switch de-energize the alarm circuits. The "Alarm Silence" switch also functions while the "Test" switch is operated.

THEORY OF OPERATION

A.C. power is connected to terminals TB-1 & 2 and flows through Fuse F1, to the power transformer TF1. TF1 reduces the A.C. line voltage to 24V and supplies it to the PC board through Fuse F2 where it rectifies the A.C. to D.C. voltage to provide 24 V.D.C. control bus for alarm sensing, signal lamps and the audible alarm.

FAILURE CONDITIONS:

Failure Contact (See Schematic) senses a failure and closes to energize the corresponding signal lamp. Relay RK2 also becomes energized. RK2 closes contacts RK2A to energize relay RK11 through normally closed RK21B. Contacts RK11A close to energize the audible alarm and relay K1. Relay K1 transfers its contacts K1A & K1B to initiate the external remote alarm contacts (See Schematic).

REPLACEMENT PARTS LIST

MODEL SRAP REMOTE ALARM PANELS

<u>PART NUMBER</u>	<u>DESCRIPTION</u>
201512	Fuse 0.4 Amps
201552	Fuse 1.0 Amps
800422	Relay - K1
400013	Fuse Holder
401696	Lamp Socket
301006	Lamp Lens - Clear
301000	Lamp Lens - Red
301316	Lamp Bulb - 36V (#1822)
304815	Transformer - TF1
400458	Sonalert
400268	Test Switch
400268	Alarm Silence Switch

NOTE: When ordering replacement parts, be sure to specify SERIAL NUMBER and MODEL NUMBER of the alarm panel in which they are to be used.

MASTER CONTROL SYSTEMS, INC.
910 North Shore Drive
Lake Bluff, Illinois 60044 U.S.A.
Phone: 847-295-1010 Fax: 847-295-0704

SRAP-3 Remote Alarm Panel

MASTER

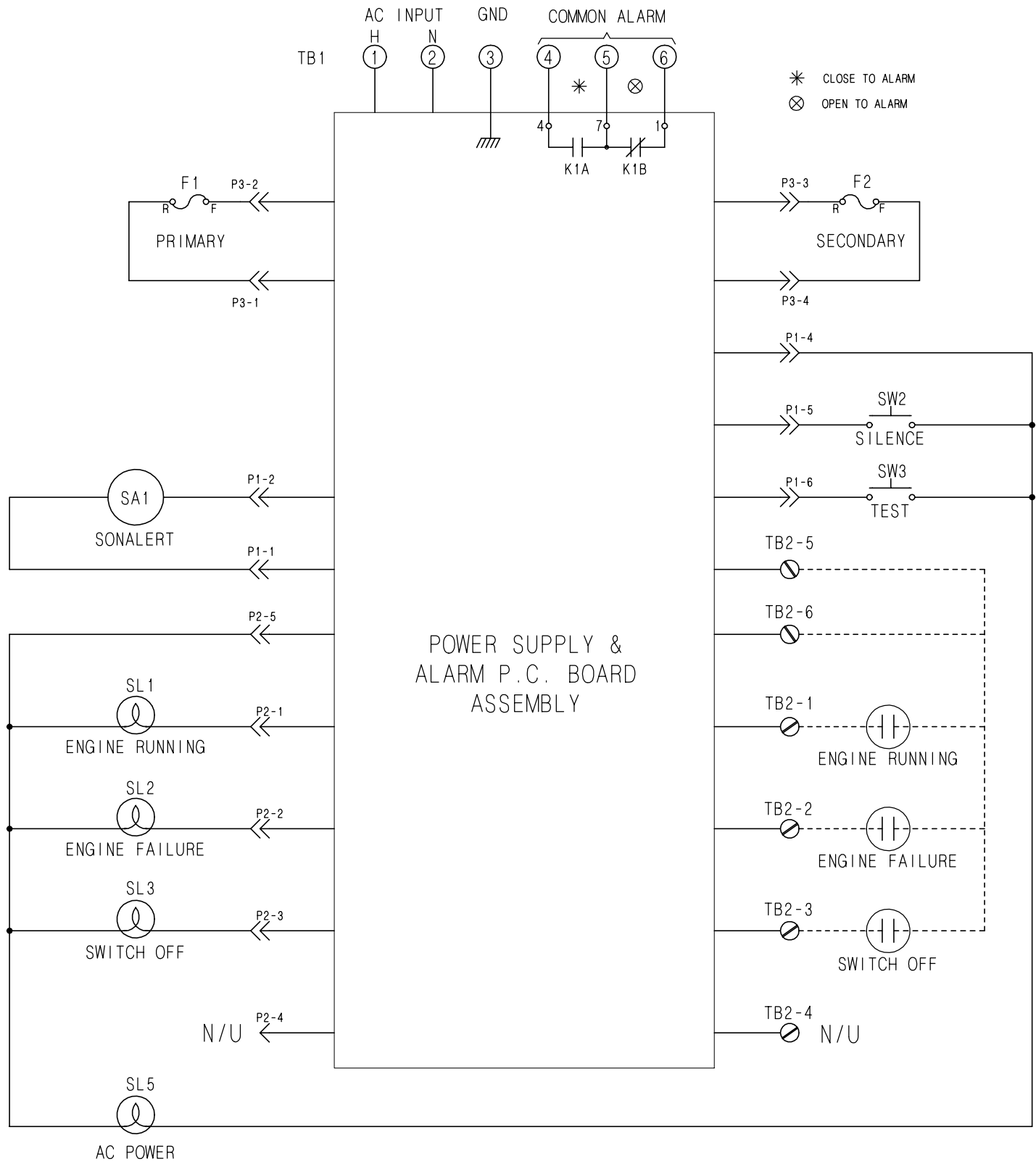

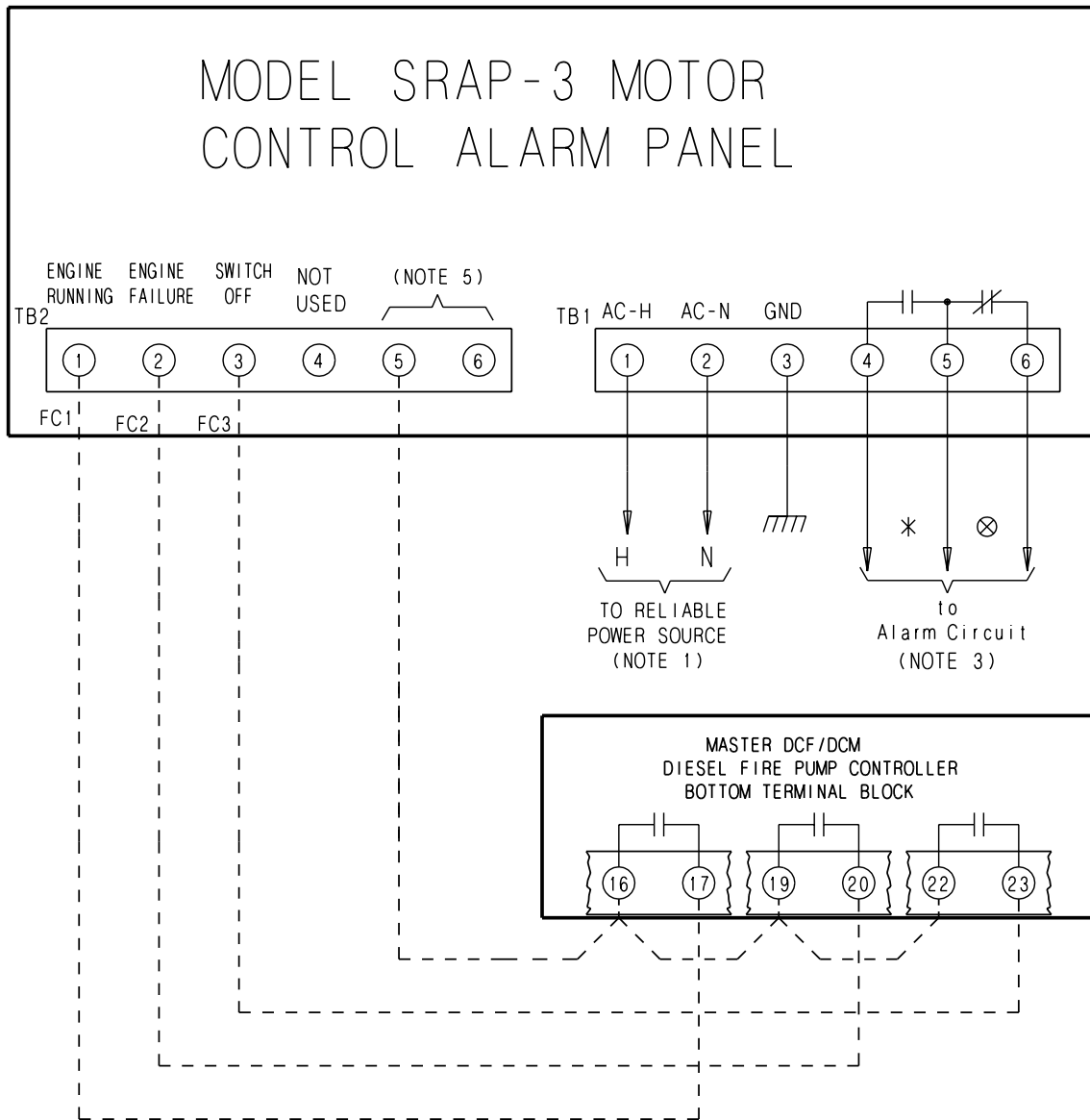

NOTES

1. 0.2 AMP. MAX. DRAW. SEE NAMEPLATE FOR INPUT VOLTAGE.
2. ALARM PANEL WIRING NEED NOT BE LARGER THAN #14 AWG. SEE INSTRUCTION MANUAL FOR RECOMMENDED WIRE SIZES.
3. SOURCE & SIGNAL SUPPLIED BY OTHERS. IF USED. CONTACTS SHOWN IN NON-ALARM STATE. CONTACTS RATED 5 AMPS @ 28 VDC/115 VAC.
 * - DENOTES CLOSE TO ALARM
 ⊗ - DENOTES OPEN TO ALARM
4. "GND" TERMINAL IS WIRED (BONDED) TO CABINET (FRAME). THE AC INPUT & DC ALARM CIRCUITS ARE ISOLATED FROM GROUND & EACH OTHER.
5. TERMINALS 5 AND/OR 6 MAY BE USED AS ALARM COMMON.

SRAP-3 Series Remote Alarm Panel



4 MTG. HOLES .312 DIA.
 4.875" BETWEEN CENTERS
 (RIGHT TO LEFT) .8.5"
 BETWEEN CENTER (TOP
 TO BOTTOM)

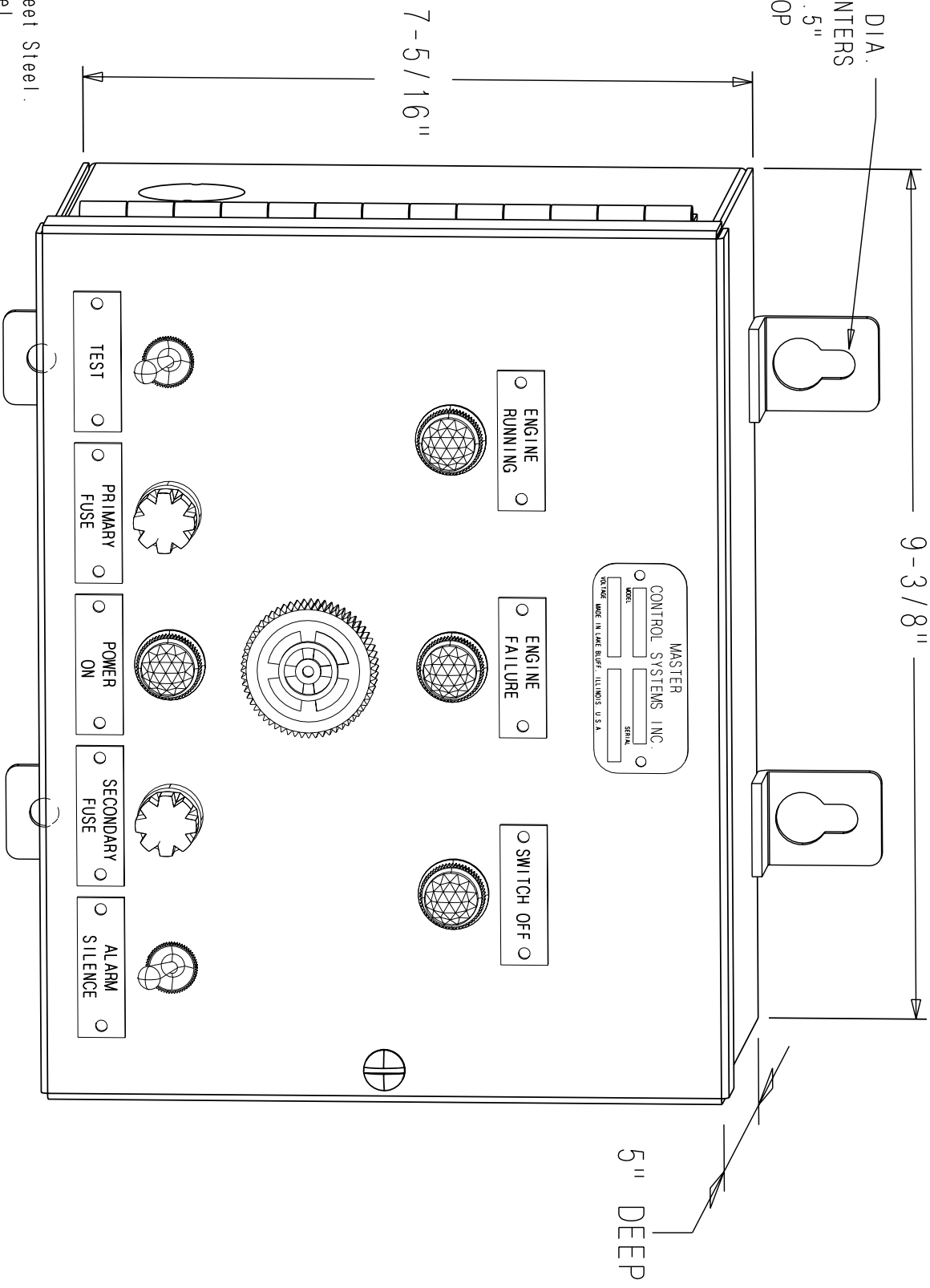

NOTES:
 Application: NEMA 1.
 Mounting: Wall Mount.
 Enclosure: 16 Gauge Sheet Steel.
 Finish: Red Baked Enamel.
 Unit Weight: 25 Pounds Maximum



A3-060

MASTER CONTROL SYSTEMS, Inc.